

Standard Equipment/Optional Equipment

Standard Equipment

- Hydrostatic power steering
- Linde twin accelerator pedals for all vehicle movements
- Central lever (joystick control) integrated into the adjustable armrest
- 2 x 9 kW maintenance free AC drive motors
- 22 kW AC maintenance free lift motor
- Different ECO modes providing the perfect combination of performance and efficiency
- Graphic display of battery operating time in minutes
- Automatic parking brake
- Linde patented combi axle in all models up to 3.5 t.
- Linde dual motor drive
- Proportional reduction of travel speed when cornering (Linde Drive Assistant)
- Seamless electronic control of all traction and hydraulic movements
- Standard chassis suitable for working in ISO containers with appropriate mast
- Hydraulically adjustable full suspension PVC operator's seat with armrest

Optional Equipment

- Single pedal accelerator with forward/reverse selector in the armrest
- Standard mast lifts up to 5,450 mm
- Duplex mast lifts (full free lift) up to 4,270 mm with 2 t. truck
- Triplex mast lifts (full free lift) up to 6,465 mm with 2 t. truck
- Alternative fork lengths
- Alternative fork carriage widths
- Integrated sideshift
- Integrated fork spreader
- Tilt cylinder protection
- Load backrest
- One, two or three additional hydraulic circuits for attachments
- Polycarbonate top screen on overhead guard
- Front and rear screens, wipers and tops screen
- Full cab with hinged doors
- Overhead guard sun blinds (front + top)
- Heating (with pollen protection filter)
- Radio with CD player
- Fabric covered comfort seat
- Super-comfort seat with air suspension, heater and backrest extension
- Swivelling seat
- Integrated charger unit, optionally with electrolytic circulation

- Comprehensive digital instrument display
- Generous storage facilities for writing materials and miscellaneous items
- Superelastic tyres
- Mast**
- Clearview standard mast 3,110 mm lift
- Fork carriage width: 1,080 mm for E20, E20/600H, E25, E25L
- 1,150 mm for E25/600H, E25/600HL, E30, E30/600 H, E30/600 HL, E30 L, E35 L, E35 HL
- Fork length 1,000 mm

- Individual or single hydraulic control joystick
- Working lamps with LED technology
- Truck lighting with LED technology (only rear lights)
- Full road lighting
- Flashing beacon/rotating beacon
- Audible reversing alarm
- External, internal and panoramic mirror
- Clipboard with LED illumination
- Cold store protection
- Active ventilation for battery charging
- Alternative custom paintwork
- Linde Fleet Management (LFM)
- Alternative tyre types
- Electrical socket 12 V

- Coming soon...May 2011
- Comfort version with +80 mm increased head clearance for all models
- Linde Safety Pilot (LSP) with load moment sensor
- Lowered chassis for battery change just with forks

Other options available on request



Electric Counterbalanced Trucks
Capacity 2000 - 3500 kg
E20, E25, E30, E35

Series 387



Safety

The protective overhead guard forms a strong and completely enclosed protective zone providing optimum structural integrity, safety and protection for the operator. The top mounted tilt cylinders provide seamless, smooth control of the tilt movements for excellent load stability in all operating conditions. This unique design also enables slimmer mast profiles to be fitted for outstanding visibility.

Performance

One would expect a high performance truck to have a high performance traction system – and that is exactly what the Linde compact drive axle and lift system delivers. Powerful motors and intelligent electronic control form an impressive power pack to deliver the highest level of productivity.

Comfort

Consistently high levels of performance and efficiency for extended periods are only possible if the operator feels comfortable. The ergonomic layout of all the controls, the adjustability of the armrest and seat, Linde Load Control, and twin accelerator pedals provide the best possible intuitive interface between the truck and the operator.

Features

- Linde compact drive axle**
- Twin drive design with high performance Linde AC technology
- Optimum energy efficiency
- Maintenance-free oil-bath vane brake
- Automatic parking brake
- Electronic components housed in sealed unit for complete protection



- Linde hydrostatic power steering**
- Minimal physical demands on the operator
- Compact ergonomically designed steering wheel
- Linde combi steer axle for outstanding manoeuvrability

- Linde twin accelerator control**
- Seamless, rapid reversing without repositioning the feet
- Short pedal travel
- Fatigue-free working
- Increased throughput and performance

- Linde Load Control**
- Small tactile joystick integrated in an adjustable armrest
- Precise and effortless fingertip joystick control of all mast functions
- Safe and highly efficient load handling

- Linde Dual Motor Drive**
- Two powerful AC drive motors integrated in the front axle
- Seamless acceleration and variable torque characteristics
- Extremely quiet in operation



- Linde operator's compartment**
- Ergonomically designed for efficient, fatigue-free working
- Spacious operator's compartment with generous floor plate area
- Cushioned comfort – mast and drive axle are isolated from the chassis and cab by a unique resilient suspension system that absorbs shock loadings



- Linde clearview mast design**
- with top mounted tilt cylinders for seamless load control and stability
- Excellent view of load and surroundings through the robust yet slim mast profiles
- Nominal capacity retained to maximum lift heights
- High residual capacities in all applications

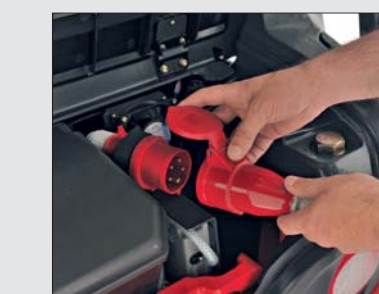

- Linde energy management**
- Optimised energy consumption
- Accurate battery condition indicator
- Simple horizontal or vertical battery changing options
- Optional built-in high frequency charger for convenience and flexibility
- Record of battery usage



Technical Data according to VDI 2198

Characteristics	Model														
	E20	E20/600H	E25	E25/600H	E25L	E25/600HL	E30	E30/600H	E30L	E30/600HL	E35L	E35HL			
1.1 Manufacturer	LINDE														
1.2 Model designation	E20														
1.3 Power unit	Battery														
1.4 Operation	Seat														
1.5 Load capacity	Q (t)	2.0	2.0	2.5	2.5	2.5	2.5	3.0	3.0	3.0	3.0	3.5	3.5		
1.6 Load centre	c (mm)	500	600	500	600	500	600	500	600	500	600	500	500		
1.8 Axle centre to fork face	x (mm)	445	445	445	468	445	468	471	471	471	476	476	476		
1.9 Wheelbase	y (mm)	1622	1651	1622	1651	1767	1796	1665	1665	1796	1810	1796			
2.1 Service weight	(kg)	4210	4825	4735	5430	4585	5445	5325	5870	5365	5830	5705	5985		
2.2 Axle load with load, front/rear	(kg)	5615 / 595	5886 / 939	6402 / 833	7082 / 848	6412 / 673	7057 / 888	7560 / 765	8000 / 870	7564 / 801	7937 / 893	8422 / 783	8547 / 938		
2.3 Axle load without load, front/rear	(kg)	2450 / 1760	2620 / 2205	2445 / 2290	2965 / 2465	2575 / 2010	3070 / 2375	2810 / 2515	3045 / 2825	2915 / 2450	3140 / 2690	3035 / 2670	3145 / 2840		
3.1 Tyres rubber, SE, pneumatic, polyurethane	SE														
3.2 Tyre size, front	23x9-10														
3.3 Tyre size, rear	180/70-8 (18x7-8)														
3.5 Wheels, number front/rear (x = driven)	2x / 2														
3.6 Track width, front	b10 (mm)	942	942	942	942	942	942	980	980	942	1028	1028			
3.7 Track width, rear	b11 (mm)	900	900	900	900	900	900	886	886	886	886	886	886		
4.1 Mast/fork carriage tilt, forward/backward	a/b (°)	5.0 / 8.0	5.0 / 8.0	5.0 / 8.0	5.0 / 8.0	5.0 / 8.0	5.0 / 8.0	5.0 / 8.0	5.0 / 8.0	5.0 / 8.0	5.0 / 8.0	5.0 / 8.0	5.0 / 8.0		
4.2 Height of mast, lowered	h1 (mm)	2247	2397	2247	2297	2247	2222	2300	2222	2222	2299	2220	2295		
4.3 Free lift	h2 (mm)	150	150	150	150	150	150	150	150	150	150	150	150		
4.4 Lift	h3 (mm)	3150	3450	3150	3200	3150	3200	3050	3200	3050	3200	3050	3200		
4.5 Height of mast, extended	h4 (mm)	3813	4113	3813	3975	3813	3975	3826	3978	3825	3977	3823	3973		
4.7 Height of overhead guard (cabin)	h6 (mm)	2080	2237	2080	2237	2080	2237	2080	2237	2080	2237	2237	2237		
4.8 Height of seat/stand-on platform	h7 (mm)	1002	1160	1002	1160	1002	1160	1002	1160	1002	1160	1002	1160		
4.12 Towing coupling height	h10 (mm)	621	656	621	658	624	659	623	656	622	661	626	659		
4.19 Overall length	l1 (mm)	3318	3352	3368	3375	3463	3520	3444	3383	3539	3528	3594	3528		
4.20 Length to fork face	l2 (mm)	2318	2352	2368	2375	2463	2520	2444	2383	2539	2528	2594	2528		
4.21 Overall width	b1/b2 (mm)	1150 / 1148	1150 / 1146	1150 / 1148	1150 / 1146	1150 / 1148	1150 / 1146	1150 / 1178	1228 / 1146	1150 / 1148	1228 / 1146	1322 / 1178	1322 / 1146		
4.22 Fork dimensions	s/e/1 (mm)	45 x 100 x 1000	45 x 100 x 1000	45 x 100 x 1000	45 x 100 x 1000	45 x 100 x 1000	45 x 100 x 1000	45 x 100 x 1000	50 x 120 x 1000	45 x 100 x 1000	50 x 120 x 1000	50 x 120 x 1000	50 x 120 x 1000		
4.23 Fork carriage to ISO 2328, class/type A, B	2A														
4.24 Width of fork carriage	b3 (mm)	1080	1080	1080	1150	1080	1150	1150	1150	1150	1150	1150	1150		
4.31 Ground clearance, below mast	m1 (mm)	130	130	129	129	130	127	136	136	136	129	129	129		
4.32 Ground clearance, centre of wheelbase	m2 (mm)	120	120	120	120	120	120	120	120	120	120	120	120		
4.33 Aisle width with pallet 1000 x 1200 across forks	Ast (mm)	3638 ¹⁾	3672 ¹⁾	3688 ¹⁾	3693 ¹⁾	3783 ¹⁾	3838 ¹⁾	3762 ¹⁾	3700 ¹⁾	3857 ¹⁾	3845 ¹⁾	3911 ¹⁾	3845 ¹⁾		
4.34 Aisle width with pallet 800 x 1200 along forks	Ast (mm)	3766 ¹⁾	3800 ¹⁾	3816 ¹⁾	3822 ¹⁾	3911 ¹⁾	3967 ¹⁾	3891 ¹⁾	3830 ¹⁾	3986 ¹⁾	3975 ¹⁾	4041 ¹⁾	3975 ¹⁾		
4.35 Turning radius	Wa (mm)	1873	1907	1923	1907	2018	2052	1973	1907	2068	2052	2118	2052		
4.36 Minimum pivoting point distance	b13 (mm)	0	0	0	0	0	0	0	0	0	0	0	0		
5.1 Travel speed, with/without load	(km/h)	20 / 20	20 / 20	20 / 20	20 / 20	20 / 20	20 / 20	20 / 20	20 / 20	20 / 20	20 / 20	20 / 20	20 / 20		
5.2 Lifting speed, with/without load	(m/s)	0.45 / 0.56	0.45 / 0.56	0.45 / 0.56	0.44 / 0.53	0.45 / 0.56	0.44 / 0.53	0.42 / 0.51	0.42 / 0.51	0.42 / 0.51	0.42 / 0.51	0.39 / 0.51	0.39 / 0.51		
5.3 Lowering speed, with/without load	(m/s)	0.54 / 0.54	0.54 / 0.54	0.54 / 0.54	0.56 / 0.56	0.54 / 0.54	0.56 / 0.56	0.56 / 0.56	0.56 / 0.56	0.56 / 0.56	0.56 / 0.56	0.56 / 0.56	0.56 / 0.56		
5.5 Tractive force, with/without load	(N)	4600 / 4600	4600 / 4600	4600 / 4600	4600 / 4600	4600 / 4600	4600 / 4600	4600 / 4600	4600 / 4600	4600 / 4600	4600 / 4600	4600 / 4600	4600 / 4600		
5.6 Maximum tractive force, with/without load	(N)	15000 / 15000	15000 / 15000	15000 / 15000	15000 / 15000	15000 / 15000	15000 / 15000	15000 / 15000	15000 / 15000	15000 / 15000	15000 / 15000	15000 / 15000	15000 / 15000		
5.7 Climbing ability, with/without load	(%)	7.6 / 11.2	6.9 / 9.8	6.5 / 10.0	5.9 / 8.7	6.6 / 10.3	5.9 / 8.6	5.6 / 8.8	5.3 / 8.0	5.6 / 8.8	5.3 / 8.1	5.1 / 8.2	4.9 / 7.9		
5.8 Maximum climbing ability, with/without load	(%)	25.4 / 39.0	23.0 / 33.4	21.6 / 34.1	19.7 / 29.3	22.1 / 35.4	19.6 / 29.3	18.7 / 30.0	17.5 / 27.0	18.6 / 29.7	17.6 / 27.2	16.8 / 27.8	16.3 / 26.4		
5.9 Acceleration time, with/without load	(s)	upon request	upon request	upon request	upon request	upon request	upon request	upon request	upon request	upon request	upon request	upon request	upon request		
5.10 Service brake	hydr./mech.														
6.1 Drive motor, 60 minute rating	(kW)	2x 9	2x 9	2x 9	2x 9	2x 9	2x 9	2x 9	2x 9	2x 9	2x 9	2x 9	2x 9		
6.2 Lift motor rating at S3 15%	(kW)	22	22	22	22	22	22	22	22	22	22	22	22		
6.3 Battery according to DIN 43531/35/36 A,B,C,no	43 536 / A														
6.4 Battery voltage/rated capacity (5h)	(V/Ah)	80 / 460-500	80 / 560-620	80 / 460-500	80 / 560-620	80 / 575-625	80 / 700-775	80 / 460-500	80 / 560-620	80 / 575-625	80 / 700-775	80 / 575-625	80 / 700-775		
6.5 Battery weight (± 5%)	(kg)	1210	1558	1210	1558	1458	1863	1210	1558	1458	1863	1458	1863		
6.6 Power consumption according to VDI cycle	(kWh/h)	6,4	7	7,5	7,9	7,3	7,9	8,6	8,7	8,6	8,7	9,5	9,8		
8.1 Type of drive control	Digital/stepless														
8.2 Operating pressure for attachments	(bar)	170	170	170	170	170	170	170	170	170	170	170	170		
8.3 Oil flow for attachments	(l/min)	50	50	50	50	50	50	50	50	50	50	50	50		

1) Including a 200 mm (min.) operating aisle clearance.

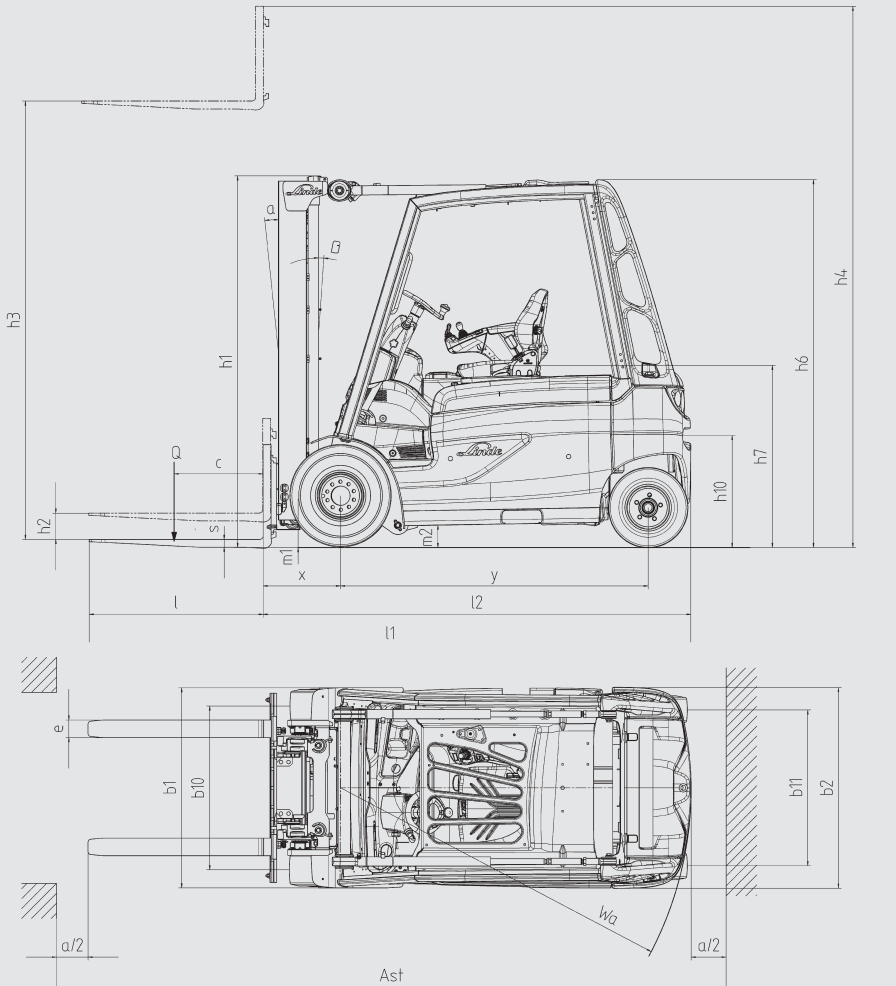

Standard mast	E20 E25 E25L	E20/600H E30 E30L E35L	E25/600H E25 E25L	E30/600H E30L E35L	E25-600H E30 E30L E35L	E25-600HL E30L E30-600H E35L						
Lift	h3	3150	3450	3750	4050	4550	3050	3200	3650	4050	4450	4950
Mast retracted	h1	2247	2397	2547	2697	2947	2225	2300	2524	2724	2924	3174
Mast extended	h4	3813	4113	4413	4713	5213	3828	3978	4428	4828	5228	5728
Free lift	h2	150	150	150	150	150	150	150	150	150	150	150

Duplex mast	E20 E25 E25L	E20/600H E25 E25L	E30 E30L E35L	E25-600H E30 E30L E35L	E25-600HL E30L E30-600H E35L		
Lift	h3	3170	3770	2925	3215	3765	4065
Mast retracted	h1	2174	2474	2081	2226	2501	2651
Mast extended	h4	3832	4432	3652	3942	4442	4742
Free lift	h2	1511	1811	1274	1424	1674	1824

Triplex mast	E20 E25 E25L	E20/600H E25 E25L	E30 E30L E35L	E25-600H E30 E30L E35L	E25-600HL E30L E30-600H E35L							
Lift	h3	4715	4865	5165	5515	5965	6465	4350	4780	5355	5955	6455
Mast retracted	h1	2174	2224	2324	2474	2624	2824	2074	2224	2449	2649	2849
Mast extended	h4	5378	5528	5828	6178	6628	7128	5125	5555	6130	6730	7230
Free lift	h2	1511	1561	1661	1811	1961	2161	1299	1449	1674	1874	2074

Figures in mm
Figures for other equipments and triplex masts on request